

THIS DRAWING IS UNPUBLISHED. RELEASED FOR PUBLICATION
 © COPYRIGHT BY TYCO ELECTRONICS CORPORATION. ALL RIGHTS RESERVED.

LOC	DIST	REVISIONS			
P	LTR	DESCRIPTION	DATE	DWN	APVD
GP	00	M	REVISED PER ECO-08-005709	18FEB08	JDP/CWR

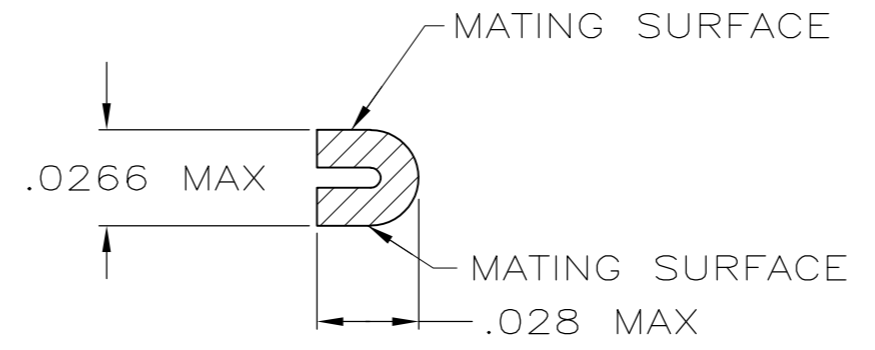
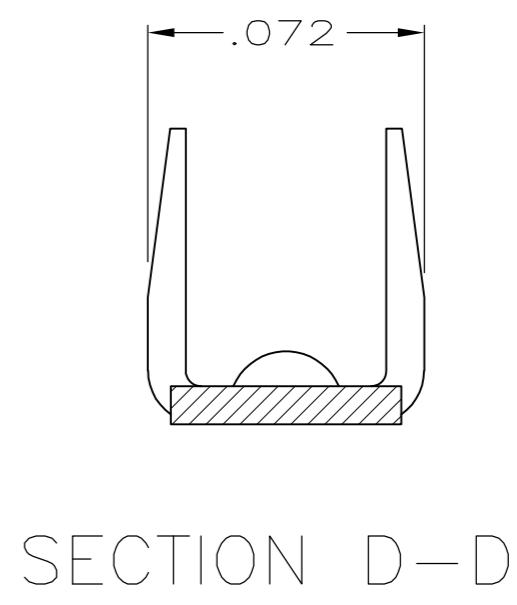
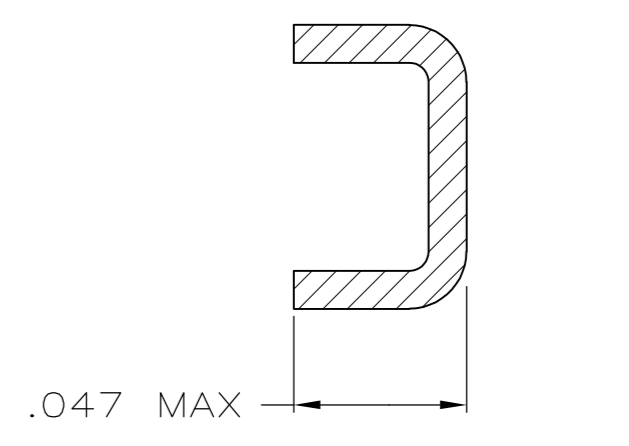
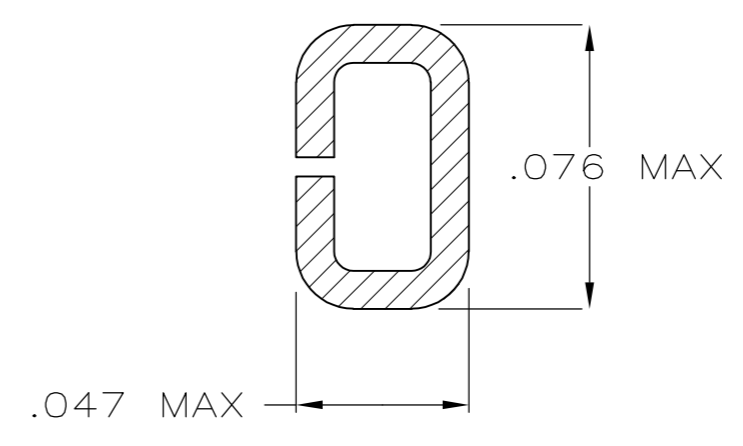
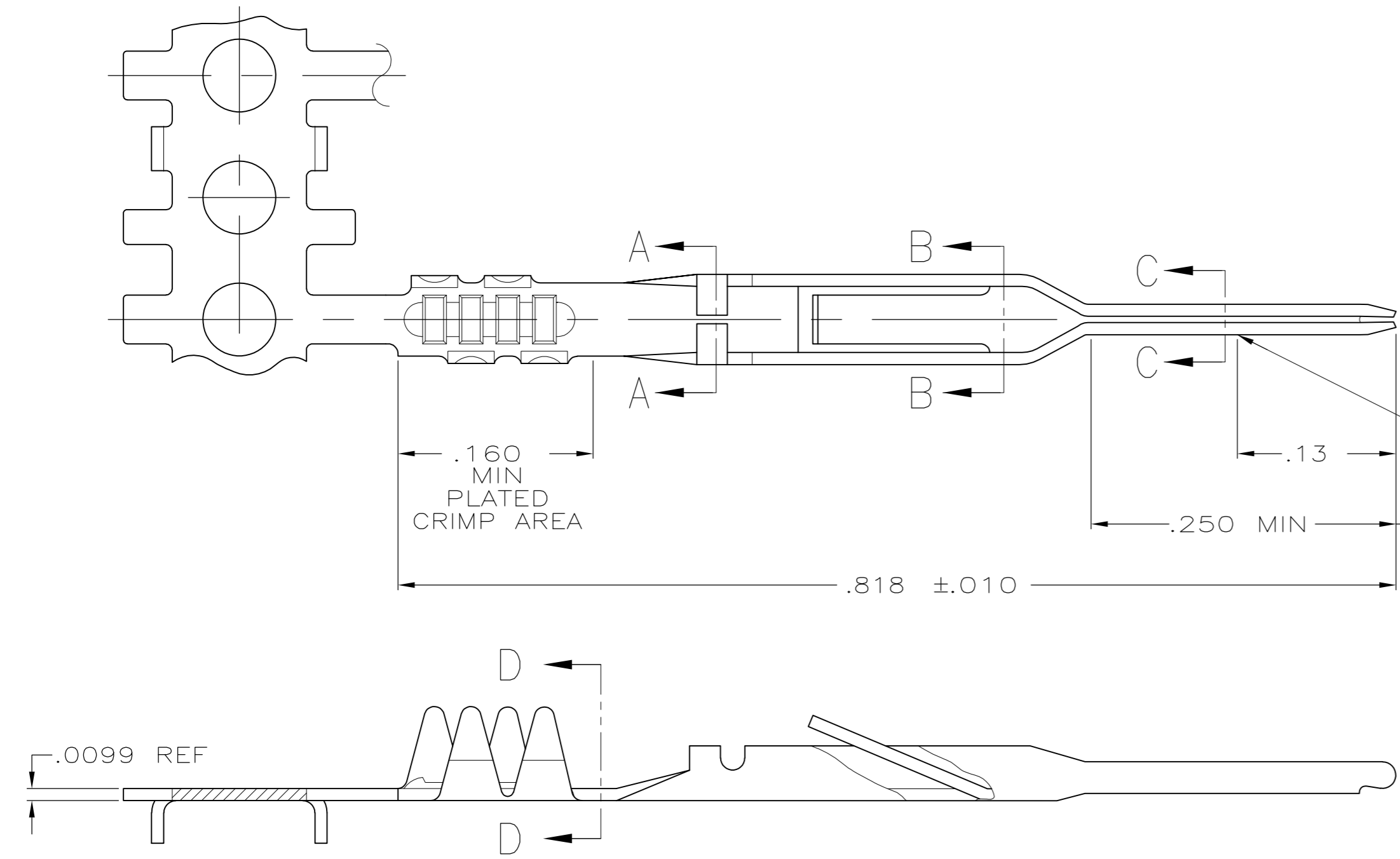

- 1 NICKEL UNDERPLATE .000050 MIN THK ON ENTIRE CONTACT WITH GOLD .000050 THK ON LOCALIZED PLATE AREA AND BRIGHT TIN-LEAD .000100 MIN THK IN CRIMP AREA
- 2 NICKEL UNDERPLATE .000050 MIN THK ON ENTIRE CONTACT WITH GOLD .000015 THK ON LOCALIZED PLATE AREA AND BRIGHT TIN-LEAD .000100 MIN THK IN CRIMP AREA
- 3 NICKEL UNDERPLATE .000050 MIN THK ON ENTIRE CONTACT WITH GOLD .000030 THK ON LOCALIZED PLATE AREA AND BRIGHT TIN-LEAD .000100 MIN THK IN CRIMP AREA
- 4 BRIGHT TIN-LEAD .000100 MIN THK OVER NICKEL UNDERPLATE .000050 MIN THK ON ENTIRE CONTACT.
- 5 GOLD .000030 THK ON ENTIRE CONTACT, EXCEPT .000003 MIN THK PERMISSIBLE ON INTERIOR OF CONTACT NOSE, OVER NICKEL .000050 THK ON ENTIRE CONTACT.
- 6 GOLD FLASH IN PLATED CRIMP AREA, .000100 MIN TIN ON LOCALIZED PLATE AREA, BOTH OVER .000050 MIN NICKEL ON ENTIRE CONTACT.
- 7 .000050 MIN GOLD ON LOCALIZED PLATE AREA, GOLD FLASH IN PLATED CRIMP AREA, BOTH OVER .000050 MIN NICKEL ON ENTIRE CONTACT.
- 8 .000015 MIN GOLD ON LOCALIZED PLATE AREA, GOLD FLASH IN PLATED CRIMP AREA, BOTH OVER .000050 MIN NICKEL ON ENTIRE CONTACT.
- 9 .000030 MIN GOLD ON LOCALIZED PLATE AREA, GOLD FLASH IN PLATED CRIMP AREA, BOTH OVER .000050 MIN NICKEL ON ENTIRE CONTACT.

9	1-88117-0
8	88117-9
7	88117-8
6	88117-7
OBSOLETE 5	88117-6
4	88117-5
3	88117-4
2	88117-3
1	88117-2
FNSH	PART NO

THIS DRAWING IS A CONTROLLED DOCUMENT.		DWN P.BERRY 3-21-86	Tyco Electronics Corporation Harrisburg, PA 17105-3608	
DIMENSIONS: INCHES		CHK D.R.WORTHINGTON 3-24-86	NAME CONTACT, .025 SQ PIN	
TOLERANCES UNLESS OTHERWISE SPECIFIED:		APVD -	PRODUCT SPEC -	
0 PLC ± -		APPLICATION SPEC 114-16015		
1 PLC ± -		SIZE A2		
2 PLC ± .02		CAGE CODE 00779		
3 PLC ± .005		DRAWING NO C=88117		
4 PLC ± -		RESTRICTED TO -		
ANGLES ± -		SCALE NTS		
FINISH SEE TABLE		SHEET 1 of 1		
MATERIAL PHOS BRONZE		REV M		
CUSTOMER DRAWING				